



NORTHERN PLASTICS

Experts in CNC Machining Precision Injection Tools and Moulded Components

(ISO 9001:2015)

Address: E - 54, Sector - 8,
Noida 201301, (U.P) India.

Contact Person : Mr. Harshul Gupta

Ph. +91-9310398366/+91-9811019773

E-mail : Harshul.Gupta@northernplastics.in

COMPANY PROFILE

- **Northern Plastics** is a one-stop shop for CNC Machining, Precision Injection Mold Design, Mold Manufacturing, Prototyping, Injection Molding, Mass Production, Assembly, Testing & Validation.
- We are based in Noida - National Capital Region (NCR) and manufacture **high precision CNC Machined parts, precision injection molds and molded components**. We work for industries like Water Purifier, Home appliances, Switch Gear, Automobile, FMCG Etc. and General Engineering. Our aim is to become the leader in CNC Machining services, precision injection molds and molded components.
- Our work experience and expertise includes working with variety of Plastics such as PP, PPCP, PC Plain & Filled, ABS, Nylon-6 & 66, Glass Filled & Mineral Filled Nylon, Delrin, HIPS, LLDPE, Acrylic etc.
- We use latest 3D software for designing, and the latest computerized equipment for Machining. Our molding machines are the industry leading servo driven PLC controlled, ranging from 60 to 200 tons of clamping force.

OUR VALUES

- **Commitment** – We do as we say, and we say as we do. This is the core value imbibed in every member of our organization.
- **Service** – We are here to serve our customer and the community, through our hard work and commitment.
- **Respect and Teamwork** – We Respect the diversity each member brings to the table and along with that their unique strengths, coupled with Teamwork to propel us forward in our goals. We live these values in our everyday activities.
- **Performance** – We go the distance and then some, that is our strength.
- **Loyalty** – is a two-way street, We're asking for it from you, then you're getting it from us.

QUALITY POLICY

- We are committed to manufacture and timely supply quality. Precision Machined Components & Assemblies to our customers to win and sustain their satisfaction by complying international standards related to QMS in our Operations. We shall ensure continual improvement in the Quality Management System, through up gradation in infrastructure, systems, processes and competence of our team.
- ISO 9001:2015

ZERTIFIKAT ♦ CERTIFICATE ♦ CERTIFICADO ♦ CERTIFICATE



Certificate of Registration

This is to certify that

NORTHERN PLASTICS

REGISTERED ADDRESS:- PLOT NO. 54, BLOCK-E, SECTOR-8, NOIDA, GAUTAM BUDDHA NAGAR, UTTAR PRADESH-201301, INDIA.

Has been assessed and found in as per ISO 9001:2015 compliance to the Requirement of standard details below.

ISO 9001:2015

(QUALITY MANAGEMENT SYSTEM)

For The Following Scope Of Activities :-
MANUFACTURING OF PLASTIC MOULDED PARTS & MOULDS.

This certificate is property of Unitas Certification Services & remains valid subject to Satisfactory surveillance Audit.

Certificate No:- 1283715
Surveillance Date:- (18-FEB-2020)

Registration Date:- (19-MAR-2019)
Certificate Expiry:- (18-MAR-2022)



Chairman
Unitas Certification Services



The certificate is valid as long the organization's meet unitas certification services's requirements.
The status of the certificate may be checked at www.unitascertificationservices.co.uk

UNITAS CERTIFICATION SERVICES

Head Office : 54 Ennerdale Close, Lake, Estate, Bletchley, Milton Keynes, Buckinghamshir, MK2 3DQ-UK
website : www.unitascertificationservices.co.uk / email: info@unitascertificationservices.co.uk

SOLUTIONS

1. **Complete Mould design** – We have in-house designers with over 50 years of combined industry experience at your disposal, to provide complete tool design, DFM, and Concept sharing. We use the latest 3D software to design our moulds and validate them.
2. **Mould manufacturing** – We have a state-of-the-art in-house Toolroom, utilizing the latest machinery to carve out your next set of mould tools.
3. **Plastic Injection Moulding**– We have an array of injection moulding machines, backed by expert production engineers and operators, ready to deliver the highest quality product-on time and right.
4. **Rapid prototyping** – We have the skills and systems to deliver prototypes with precise tolerances and finishes, ready to be scaled to mass production.
5. **CNC Machining**- Using state of the art CAD software, **Northern Plastics** can mill tool paths for even the most complex parts – freeing up mould-maker resources to do the finishing work.
6. **Component validation** – We have over 93% success rate at T0 sample trial.

OUR PRODUCTS

1. Plastic Injection Tooling
 - I. Un-screw moulding tools
 - II. Hot and cold runner tools
 - III. Core pulling tools
 - IV. Insert moulding tools
2. Mould Bases and Plates
 - I. Standard bases and plates
3. Sheet Metal Tooling
4. Child Parts of Plastic injection tools.
5. Pillar Bushes, Lifters, Ejector Pins, Core and Cavity Inserts.
6. Plastic Injection Moulded Components – We serve industries such as; Water purifiers, MCCB, home appliances, automotive, switch gears etc. using engineering raw material such as Nylon-6/66 (Mineral/glass filled/unfilled), PC (filled and unfilled), ABS, POM, HIPS, PP (Homo-Polymer/Co-Polymer), LLDP, HDPE etc.
7. Custom Injection Moulded Components, using tools our customers provide, producing goods our customers require, we just make sure it's done right!

LIST OF IN-HOUSE MACHINES

- **HAAS VERTICAL MACHINING CENTER – VF-2**
- **HAAS VERTICAL MACHINING CENTER – VF-4**
- **ELECTRONICA WIRE CUT MACHINE**
- **ELECTRONICA ELECTRIC DISCHARGE MACHINING (EDM) (2)**
- **SURFACE GRINDER (3)**
- **MILLING MACHINE**
- **DRILL MACHINE**
- **HIM - 200 TONNES (2)**
- **HIM - 140 TONNES (2)**
- **HIM - 120 TONNES (2)**
- **HIM - 90 TONNES (1)**
- **VIM - VERTICAL 60 GMS – SCREW TYPE (3)**

*HIM – HORIZONTAL INJECTION MOULDING MACHINE

*VIM – VERTICAL INJECTION MOULDING MACHINE

PROCESS FLOW OF TOOL PRODUCTION

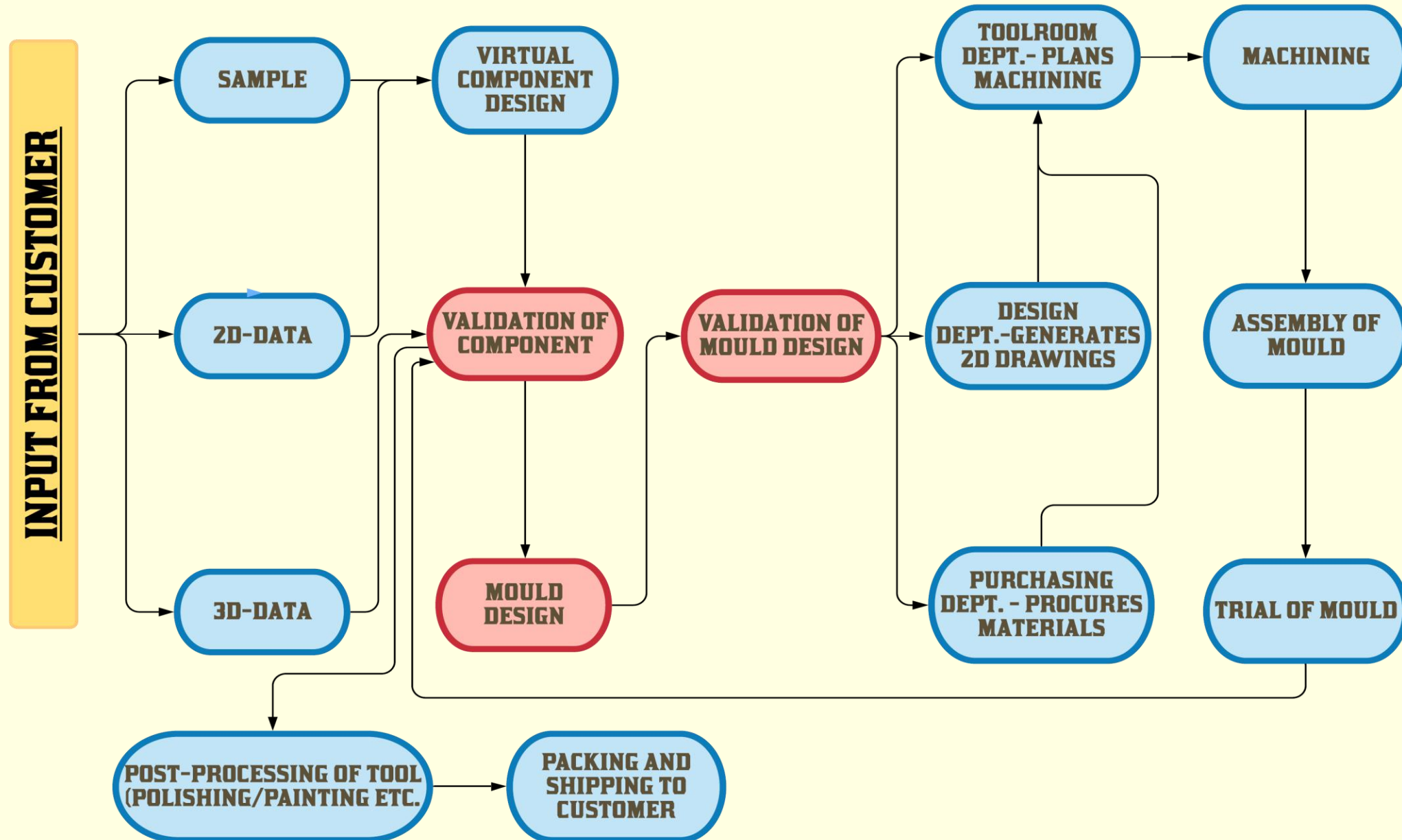

OUR PRODUCTS

TOOL OF CARTRIDGE FILTER –
FOR **EUREKA FORBES**

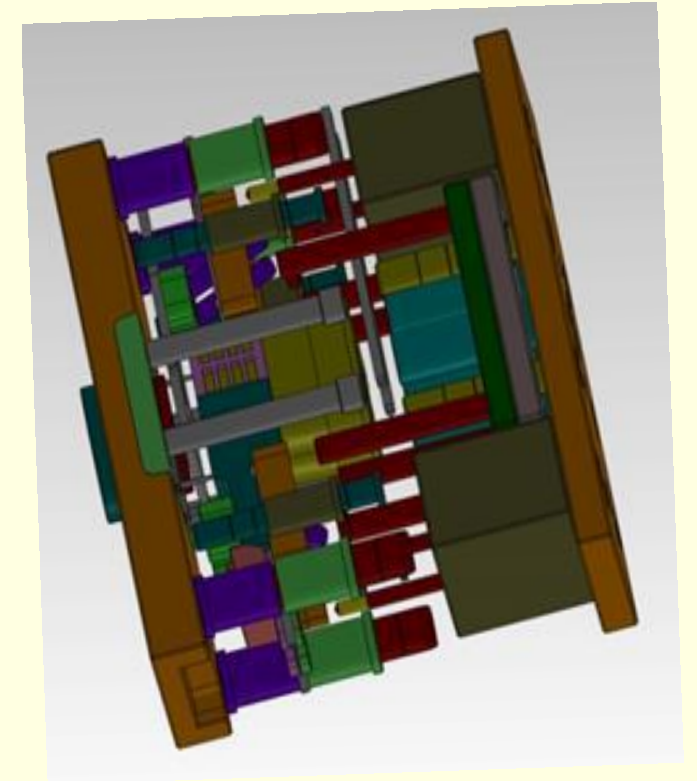
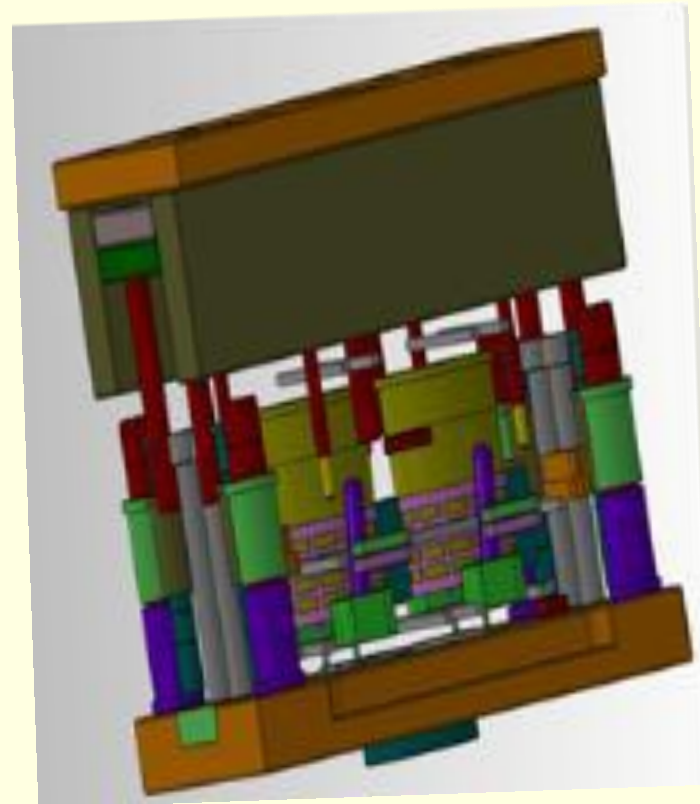
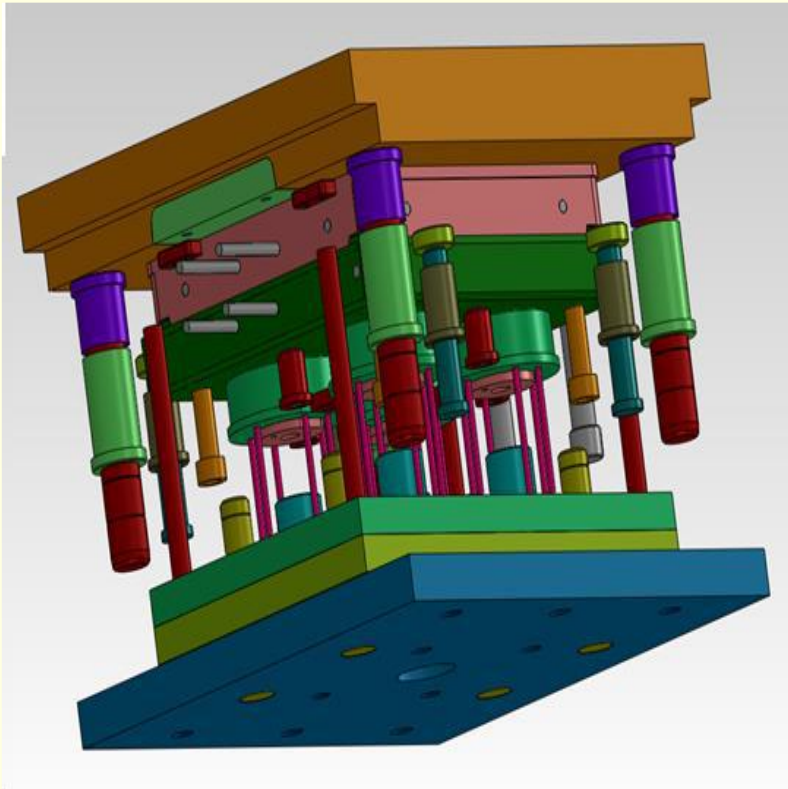

SPEAKER TOOL LAYOUT - FOR
HONEYWELL

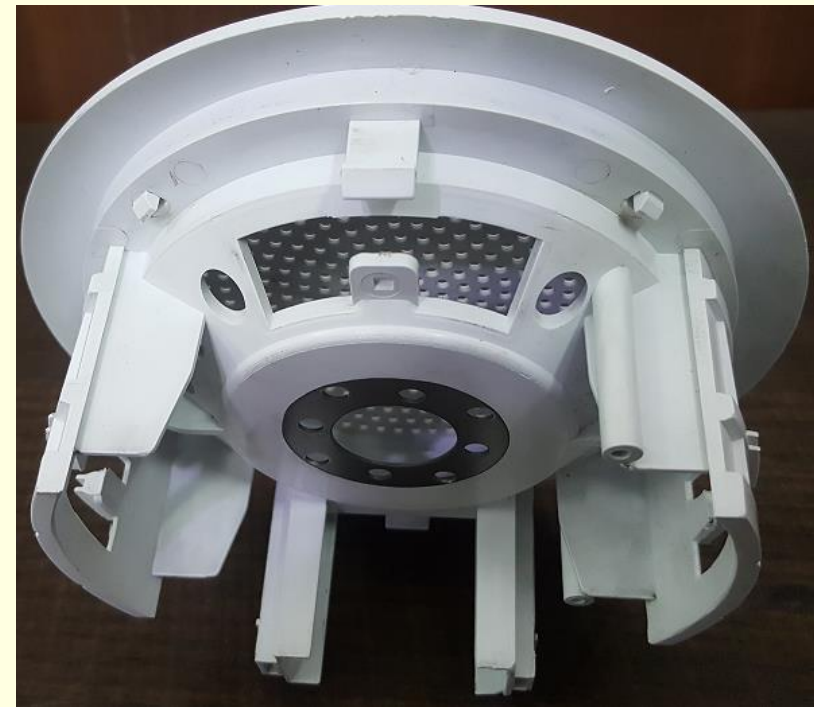
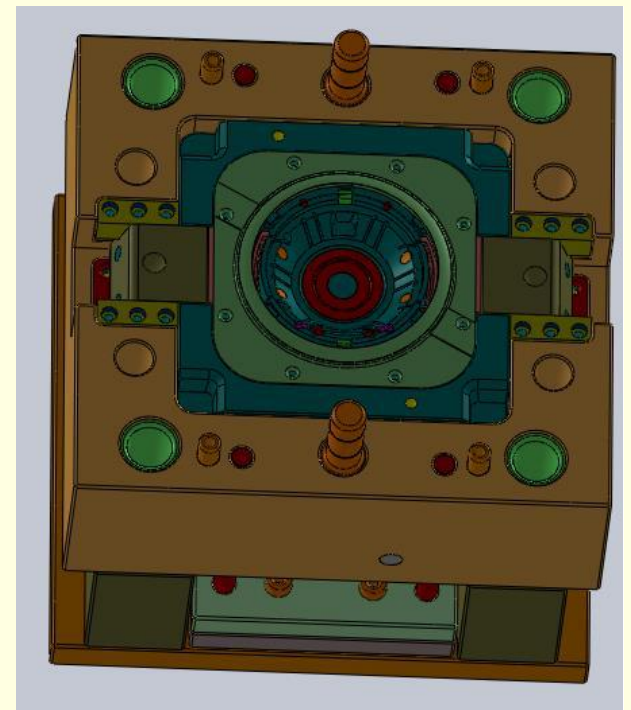
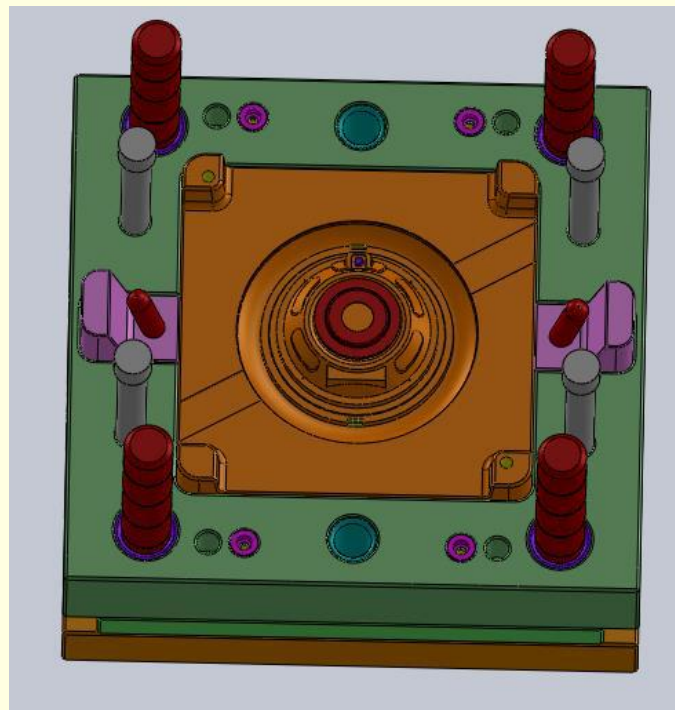

MOLD OF SPEAKER –
FOR
HONEYWELL

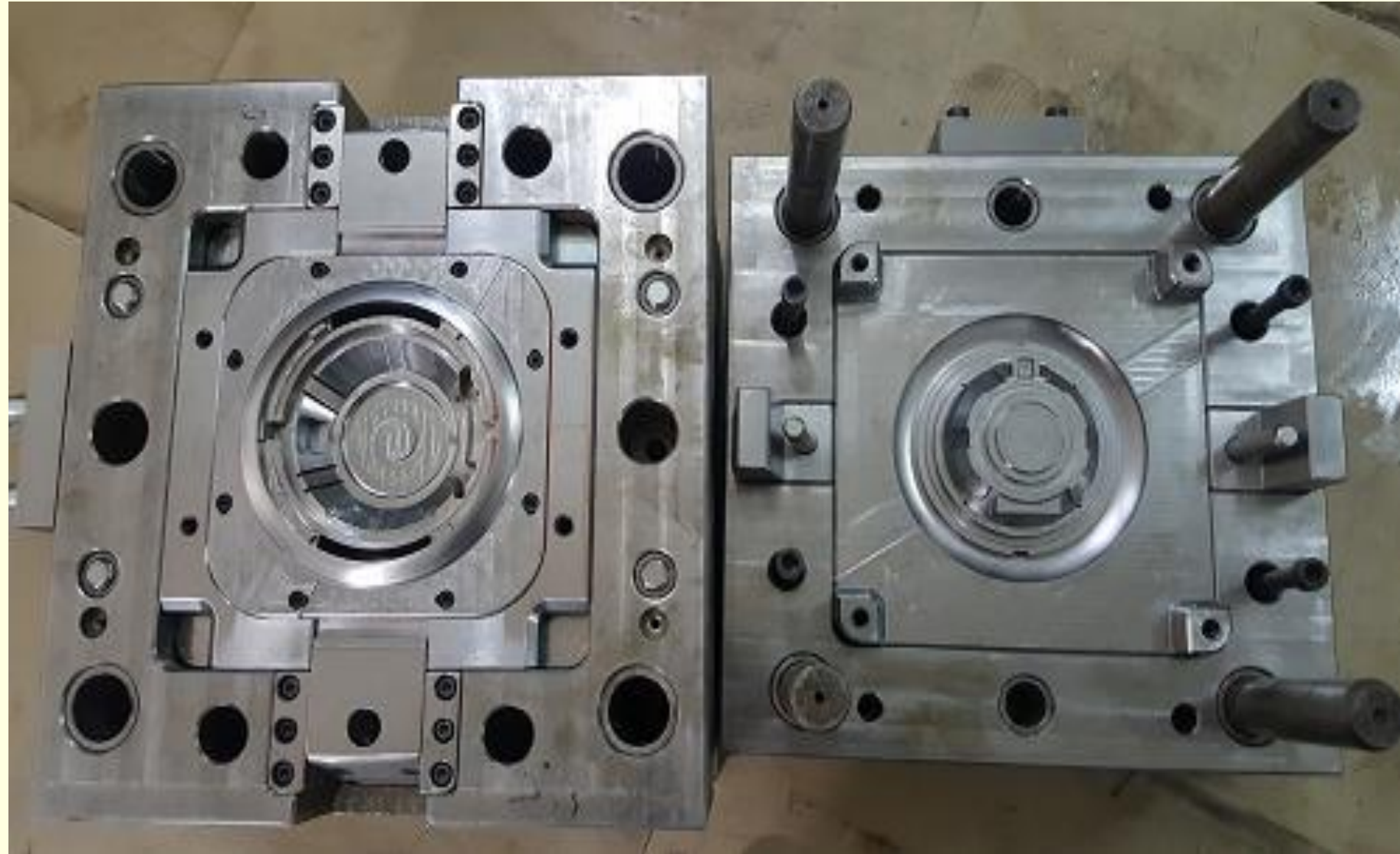

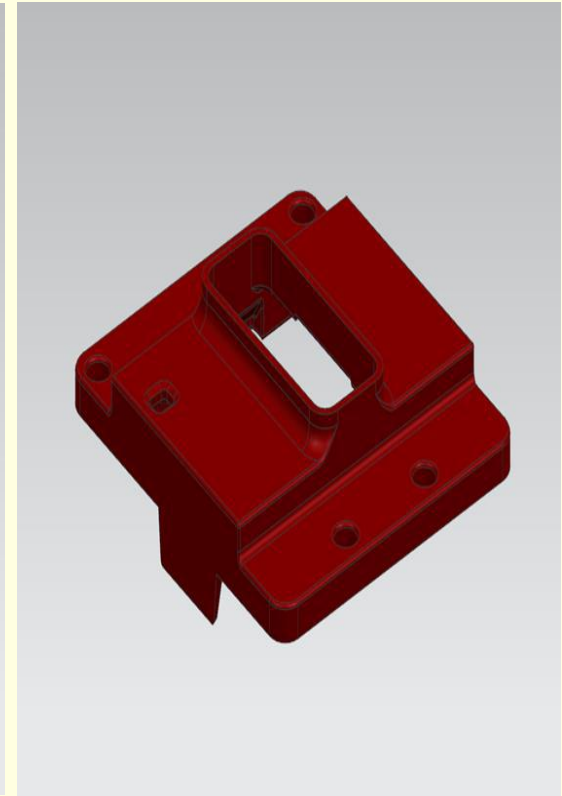
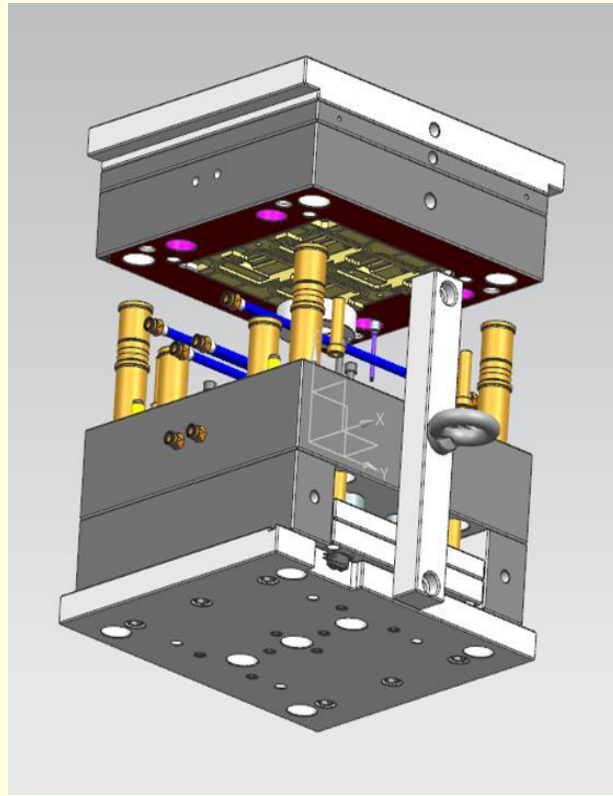
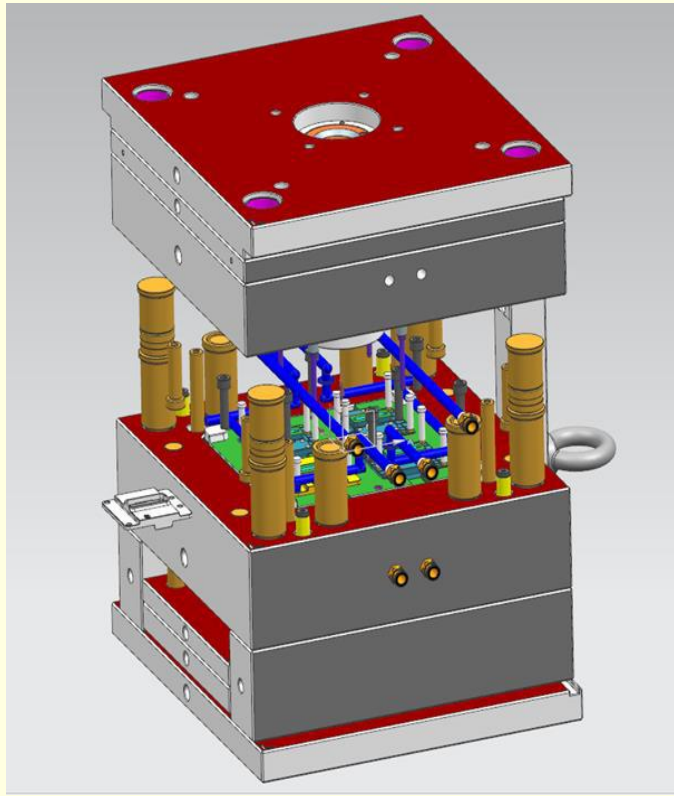

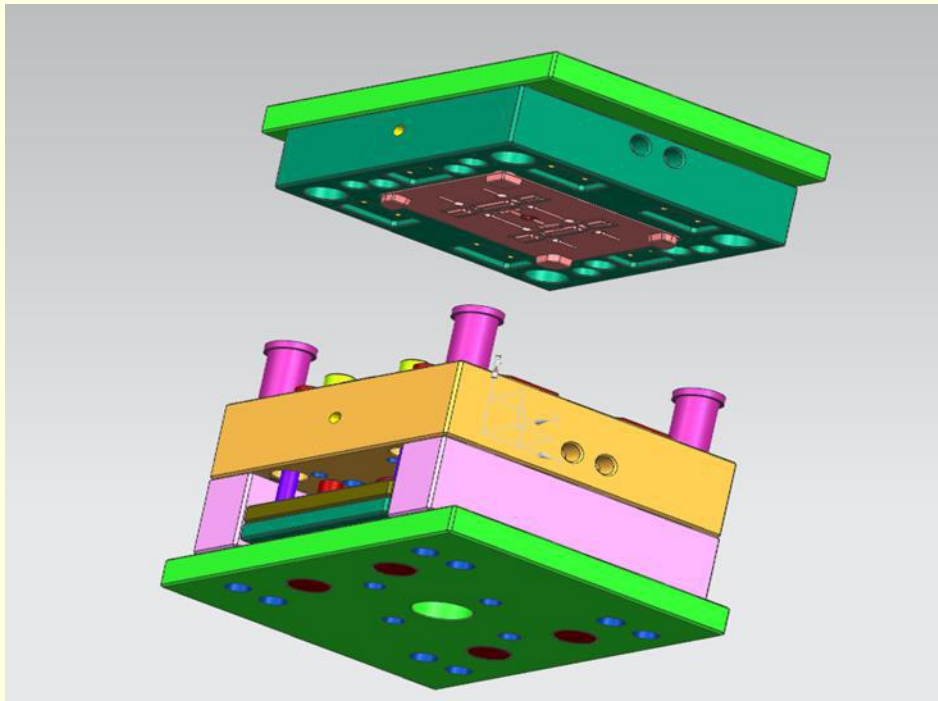
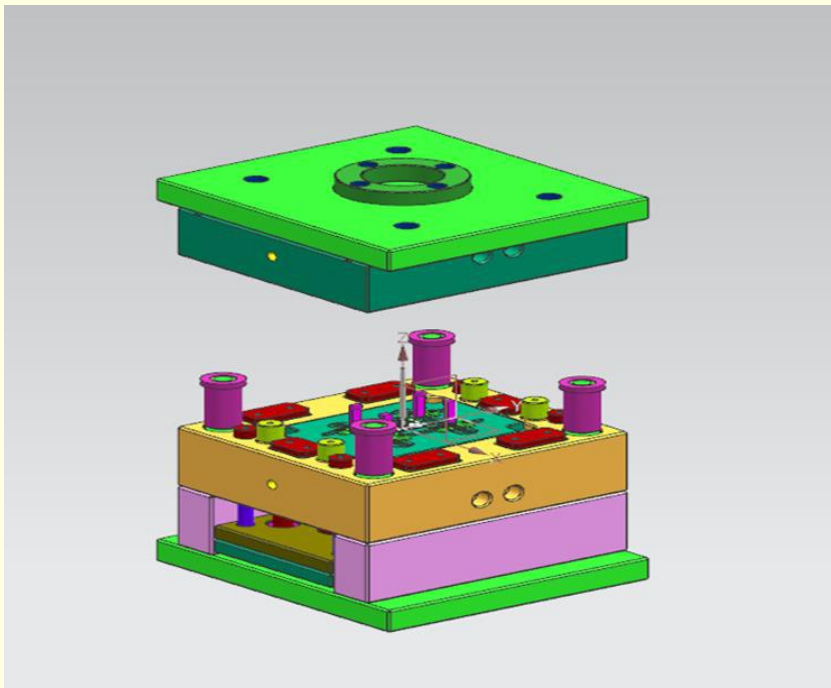

MOLD OF SPEAKER – FOR
HONEYWELL



MOLD OF SPEAKER – FOR
HONEYWELL

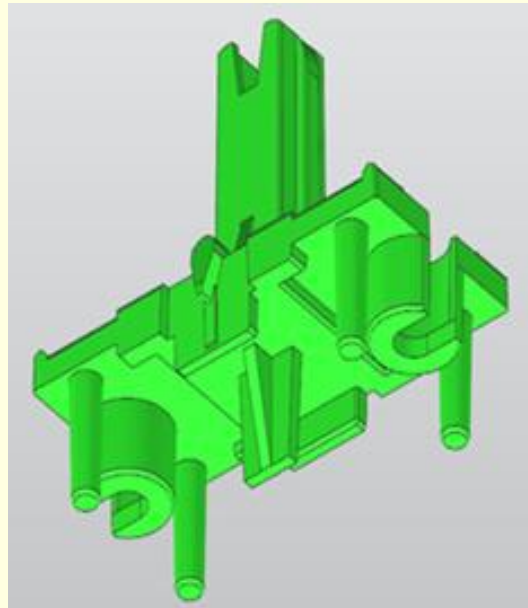

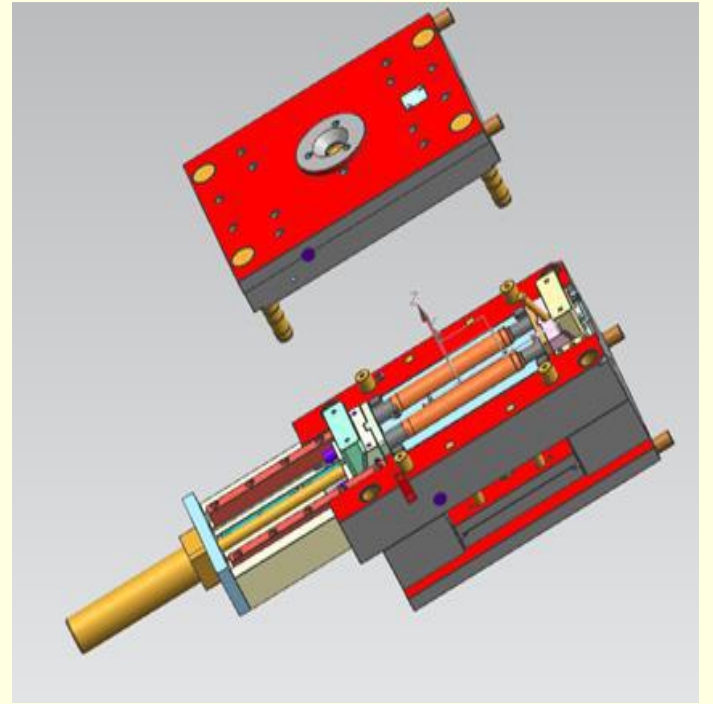
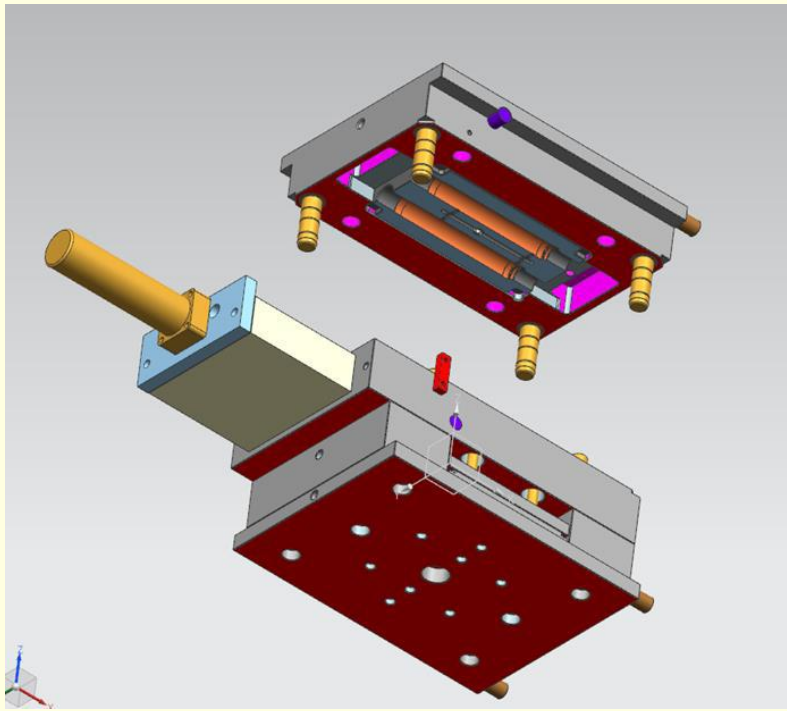

CORE-PULLING TOOL OF
MINERAL BOWL,
DEVELOPED FOR -
EUREKA FORBES

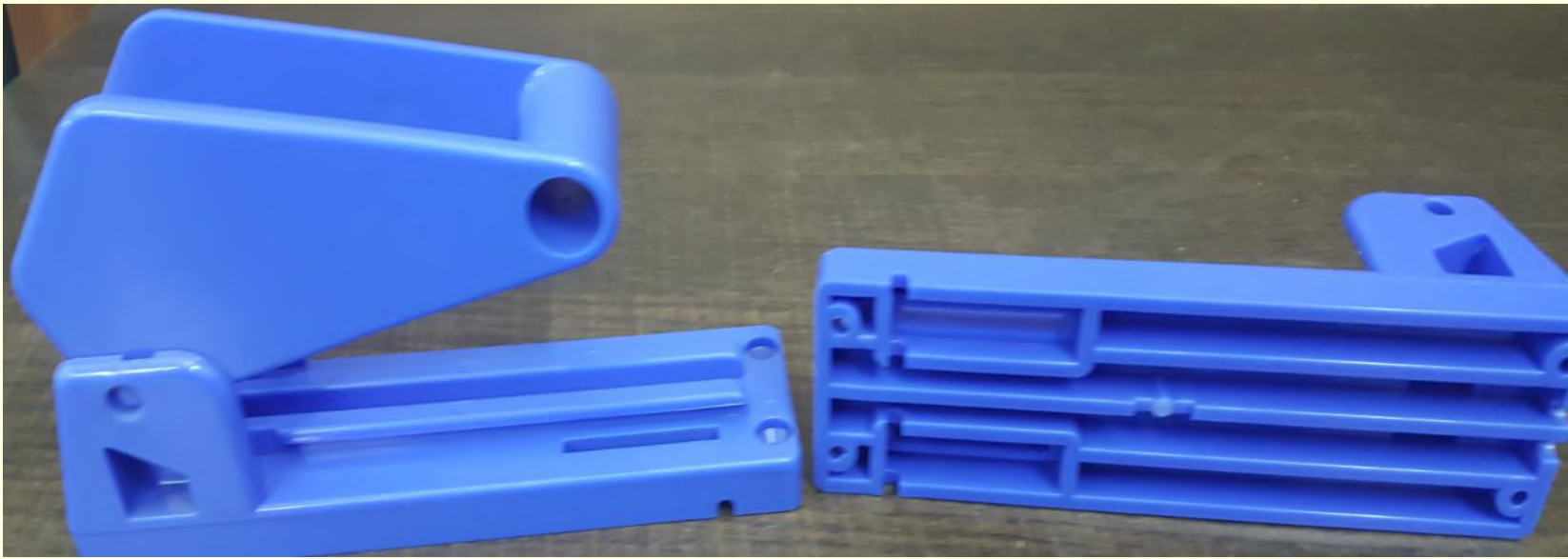

USED AT MARUTI-SUZUKI ASSEMBLY LINE
DEVELOPED FOR –

MOTHERSON
SUMI



MUTI-PURPOSE BOWL
USED IN MAIN FILTER ASSEMBLY OF RO SYSTEMS
DEVELOPED FOR –

EUREKA FORBES

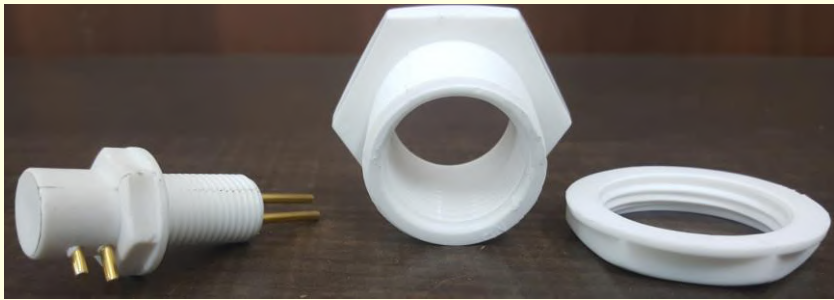

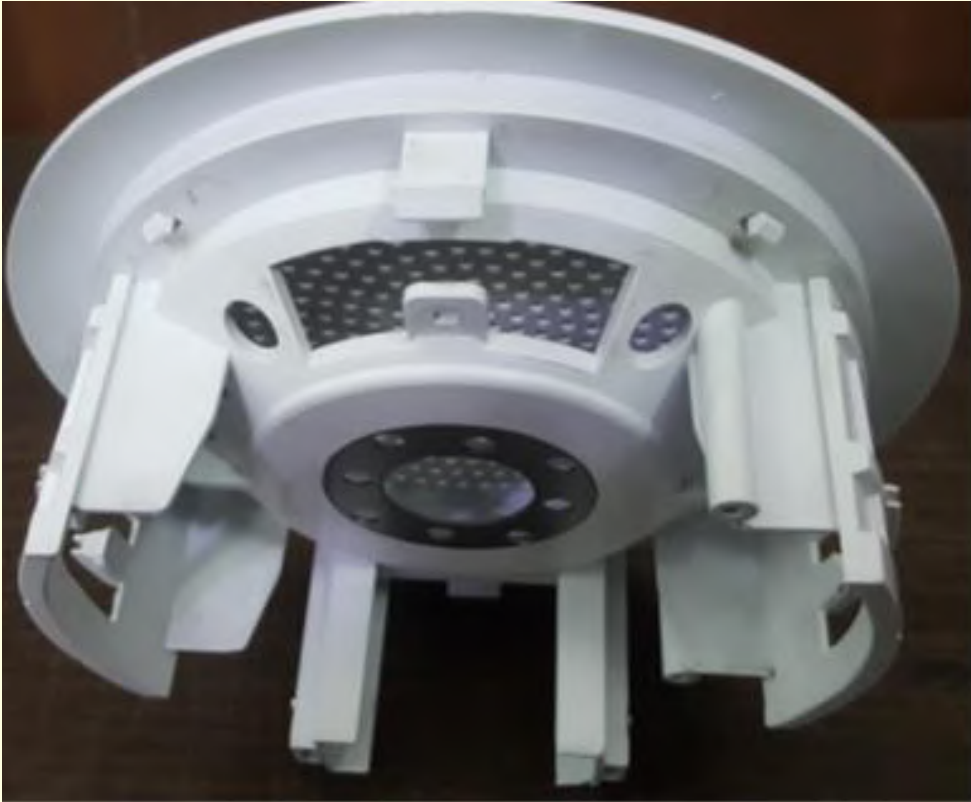
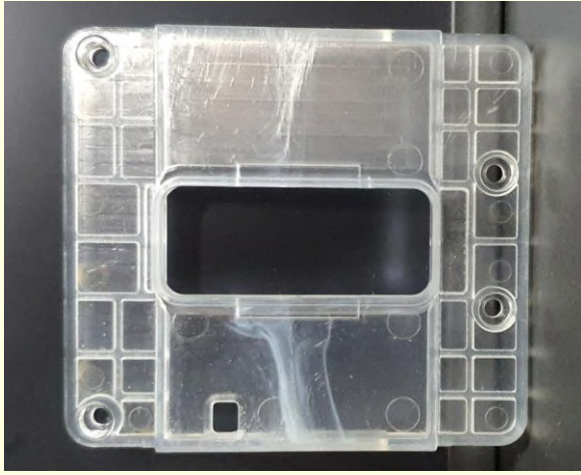
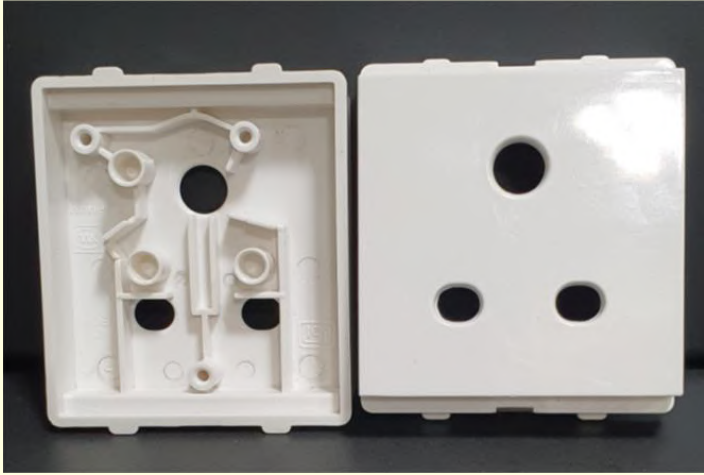



DIVERTER VALVE
ENTIRE BRASS BODY REPLACED
WITH NYLON W/ BRASS INSERTS
PATENT PENDING
DEVELOPED FOR –

EUREKA FORBES

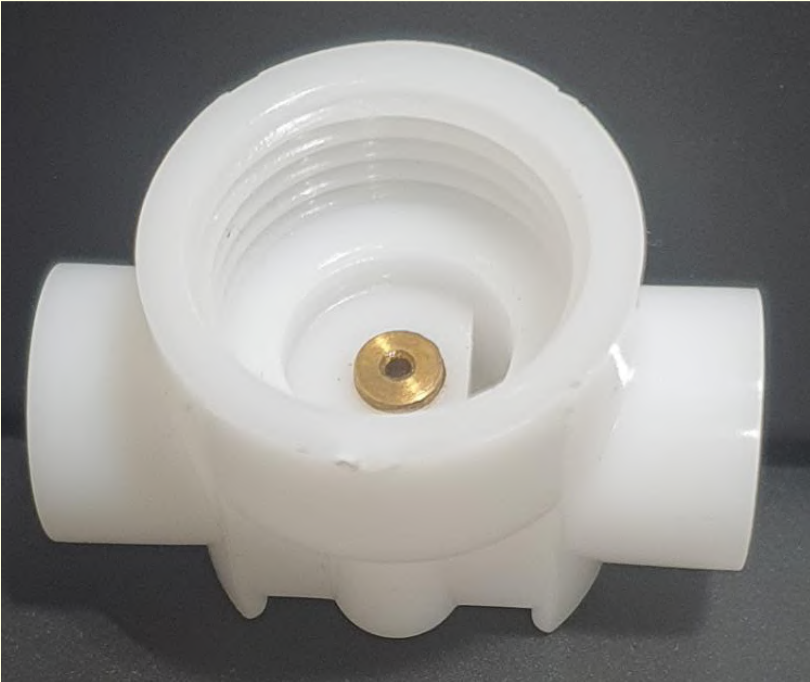



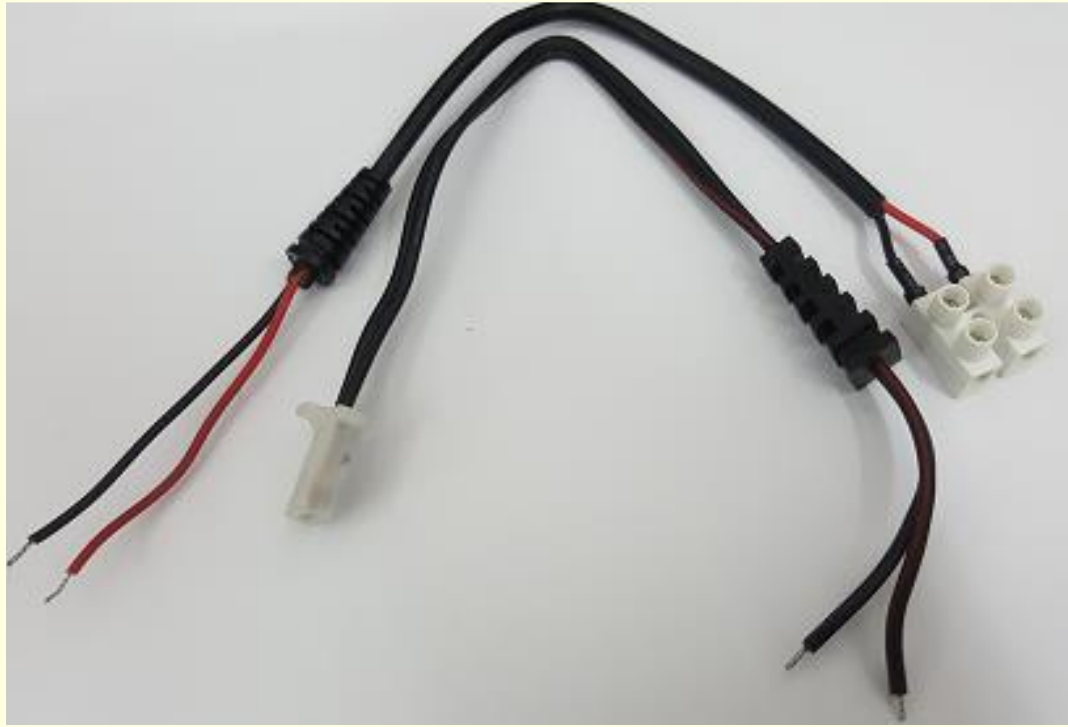

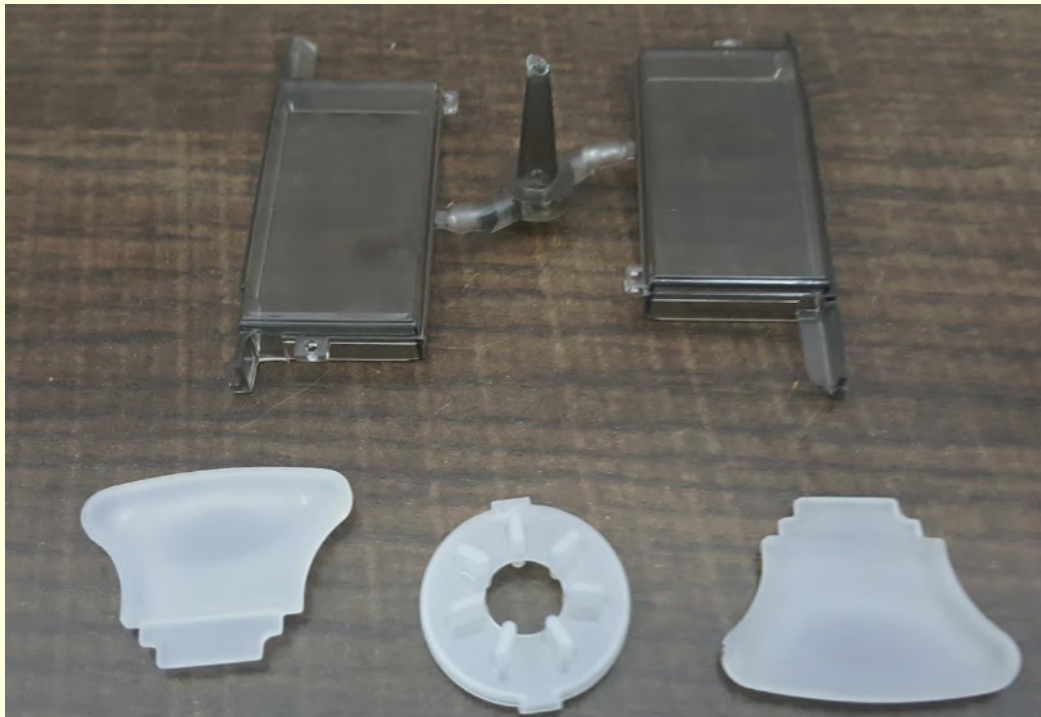

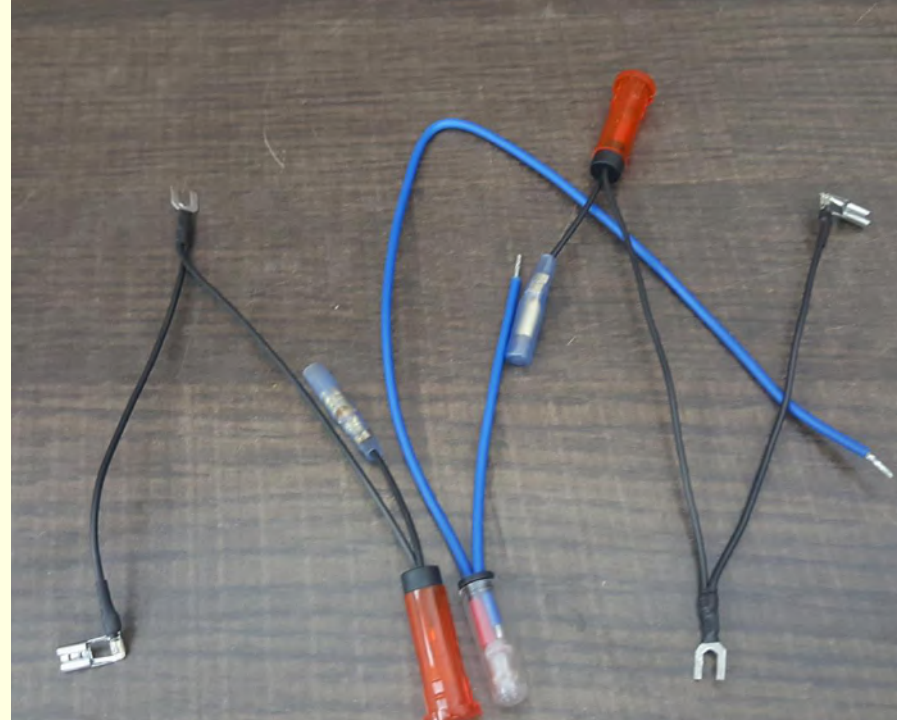

NAME	NORTHERN PLASTICS
ADDRESS	E - 54, Sector - 8, Noida (U.P.) - 201301.
TYPE OF FIRM	Proprietorship.
CONTACT PERSON	Mr. Harshul Gupta
MOBILE NUMBER	+91-9310398366 / +91-9811019773
EMAIL ID	Harshul.Gupta@northernplastics.in
TELEPHONE	0120-4269759
PAN NUMBER	AFHPG3753Q
GST NUMBER	09AFHPG3753Q1ZV
BANK	HDFC Bank Ltd.
BANK ADDRESS	BK-11, Sector-01, NOIDA
ACCOUNT NUMBER	18972020000177
NEFT/RTGS/IFSC Code	HDFC0001897

OUR CUSTOMERS

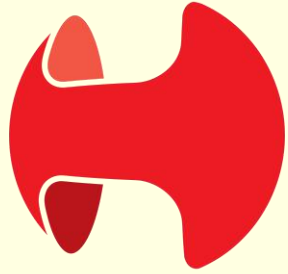

HAVELLS



Motherson Sumi Systems Limited

DS GROUP



Dharampal Satyapal Group

THANK YOU! FOR TAKING OUT YOUR PRECIOUS TIME TO LOOK AT OUR PRESENTATION.

WE WILL BE OBLIGED TO RECEIVE AN INQUIRY FROM YOU, PERTAINING ANY SERVICES WE CAN PROVIDE TO FACILITATE YOUR BUSINESS.

WE ALSO WOULD LIKE TO INVITE YOU TO OUR FACILITY FOR A VISIT, IT'LL BE OUR HONOR TO WELCOME YOU AND UNDERSTAND YOUR BUSINESS NEEDS.

THANK YOU AGAIN, AND WE LOOK FORWARD TO SPEAKING WITH YOU.

TEAM NORTHERN PLASTICS